

# **Installation and User Instructions for your Integrated Fridge Freezer Models BM10/21**

## **Retention of the Instruction Book**

This Instruction Book must be kept handy for reference as it contains important details on the safe and proper use of the appliance.

If you sell or pass the appliance to someone else, or move house and leave it behind, make sure this Book is also provided so the new owner can become familiar with the appliance and safety warnings.

**IMPORTANT INFORMATION:**

- Do not plug in and switch appliance on at the mains until installation is complete.
- You may be charged for a service call if a problem with your appliance is caused by incorrect installation or misuse.

## Electrical Supply

**WARNING: This appliance must be earthed.**

### Fuses

Your appliance comes fitted with a plug and a 13A fuse. If you need to replace the fuse, only those rated at 13A and ASTA approved to BS1362 should be used. Correct replacement is identified by colour coding or the marking on base of plug.

**WARNING: Do not use plug unless fuse cover is fitted.**

### Changing the Plug

Cut off and dispose of the supplied plug if it does not fit your socket.

**WARNING: To avoid a shock hazard do not insert the discarded plug into a socket anywhere else.**

**IMPORTANT: WIRES IN THE MAINS LEAD ARE COLOURED IN ACCORDANCE WITH THE FOLLOWING CODE:**

Green/Yellow	-	Earth
Blue	-	Neutral
Brown	-	Live

If you change the plug, the colour of wires in the mains lead may not correspond with the colour of the markings identifying terminals in the plug. You should therefore wire it as shown.

Green and yellow (Earth)  
wire to terminal  
marked 'E',  
symbol, ⊕ or  
coloured green  
and yellow.

Blue (Neutral)  
wire to terminal  
marked 'N' or  
coloured black.

13A ASTA approved  
fuse to BS1362.

Brown (Live)  
wire to terminal  
marked 'L' or  
coloured red.

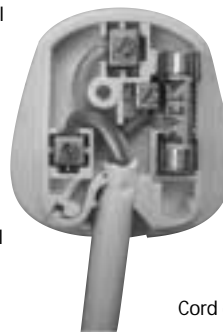

Cord clamp

### Changing the Mains Lead

A special lead can be ordered from our Service Department  
UK: 08709 066 066 or  
Republic of Ireland: 1850 302 220

If you have damaged the existing lead or require a longer one a charge will be made. It is strongly advised that this work is carried out by a qualified electrician.

**CE** CE marking certifies that this appliance conforms to the following EEC directives:-  
Low Voltage Equipment - 72/23/EEC & 93/68 EEC  
Electromagnetic Compatibility - 89/336/EEC, 92/31/EEC & 93/68/EEC

**WARNING: AVOID ACCIDENTS TO CHILDREN. WHEN DISCARDING AN OLD FRIDGE OR FREEZER BE CERTAIN TO MAKE THE LOCK UNUSABLE. IF POSSIBLE, REMOVE THE DOOR AND DISCARD SEPARATELY. DO NOT ATTEMPT TO SIT ON TOP OF YOUR APPLIANCE. IT IS NOT DESIGNED FOR SUCH USE AND YOU COULD INJURE YOURSELF OR DAMAGE THE APPLIANCE BY SUCH ABUSE.**

# Contents

	<b>Page</b>
<b>Installation</b>	
Choosing a location	4
Installation	4
Door Reversal	5-6
Mounting the appliance	7-8
<b>Get to know your Appliance</b>	9-10
<b>Getting your Appliance ready for use</b>	
Final Check	10
Running in the Compressor	10
<b>The Controls</b>	11
<b>Storing Food</b>	
Storing Fresh Food	12
Freezing Fresh Food/Procedure	13
Storing Frozen Food	13
Defrosting Frozen Food	13
<b>Caring for your Appliance</b>	
Defrosting	14
Changing the Light Bulb	14
Cleaning	15
Going Away	15
<b>Troubleshooting</b>	16
<b>After Sales Service</b>	17
<b>Guarantee</b>	18
<b>Key Contacts</b>	Back Cover

## Retention of the Instruction Book

This Instruction Book must be kept handy for reference as it contains important details on the safe and proper use of the appliance.

If you sell or pass the appliance to someone else, or move house and leave it behind, make sure this Book is also provided so the new owner can become familiar with the appliance and safety warnings.

# Installation.

**WARNING: THE APPLIANCE SHOULD ONLY BE INSTALLED BY A QUALIFIED ELECTRICIAN IN COMPLIANCE WITH THESE INSTRUCTIONS, CURRENT STANDARDS AND REGULATIONS.**

**Before Fitting:**

Before connecting to the electricity supply leave the appliance to stand for 2 hours to allow the cooling system to settle.

Please read through this section before starting any work.

At the base of the kitchen unit intended for installing the appliance, there should be at least 200cm<sup>2</sup> free space, for adequate air circulation.

Do not cover the air outlet grille at the top of the appliance.

Your Integrated Fridge Freezer is designed to fit into a tall housing as shown (fig 1). It is vitally important that the appliance is vented correctly.

**Choosing a location:**

Your Integrated Fridge Freezer should be fitted into a kitchen unit space where it is easy to use.

The power socket should be in a readily accessible position adjacent to the unit. Never place the appliance near a heat emitting device (eg. cooker, radiator, water heater or similar) and do not expose it to direct sunlight. In such a position your Fridge Freezer will have to work harder and will cost more to run and may be damaged by the heat. The appliance may be exposed to lower or higher temperatures but only for short periods of time and the temperature should never be lower than 5 °C.

The rear wall of the appliance gets warm during operation and water evaporates from the drain pan on the compressor. You must therefore provide adequate air circulation at the rear of the appliance.

A (mm)	B (mm)	C (mm)
<b>Bottom door</b>	<b>Top door</b>	<b>Cabinet</b>
BM10 653	BM10 1033	Bm10 1775-1780
BM21 846	BM21 840	BM21 1775-1780

Fig. 1

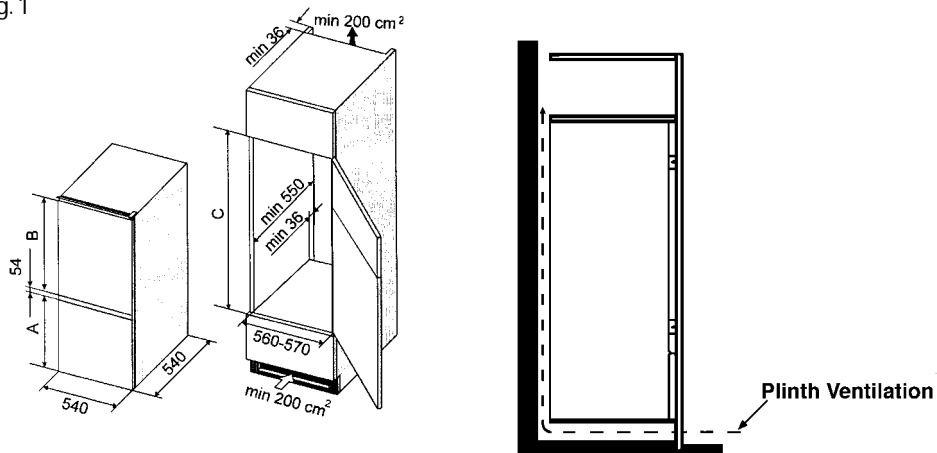

# Installation (Door reversal).

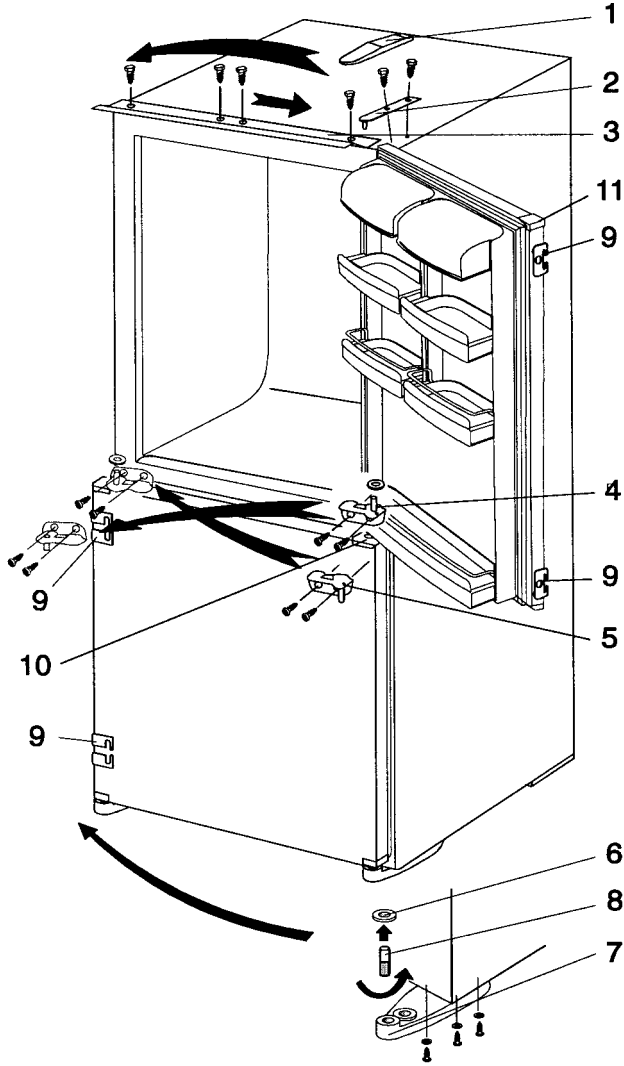

- 1. Top hinge cover of the refrigerator door.
- 2. Top hinge of the refrigerator door.
- 3. Top strip.
- 4. Bottom hinge of the refrigerator door.
- 5. Top hinge of the freezer door.
- 6. Washer.
- 7. Bottom hinge of the freezer door.
- 8. Bottom hinge filling plug of the freezer door.
- 9. Slider guide.
- 10. Corner cap with a hole.
- 11. Corner cap without a hole.

## Installation (Door reversal).

If you find that the direction of the door opening is not convenient, you can reverse it. The necessary holes on the opposite side of the cabinet have been made in the factory and plugged.

\* After you have reversed the door, check if the magnetic gasket seals correctly. It must not be creased and must seal all around the door.

- \* Remove the top hinge cover of the refrigerator door. Remove the door by unscrewing the hinge (the door is supported only by the bottom hinge) and remove the hinge washer.
- \* Unscrew the top strip, move it on the opposite side of the appliance and fasten it.
- \* Unscrew the bottom hinge and washer of the freezer door and the bottom hinge of the refrigerator door.
- \* Remove the corner caps from the door and reposition them (instead of the one with a hole insert the one without it, and vice versa).
- \* Take off the washer from the bottom hinge of the freezer door (by turning it in clockwise), unscrew the bottom hinge filling plug and screw the bottom hinge without a plug.
- \* Insert the filling plug and washer in the reverse order into the hole for the bottom hinge on the opposite side of the appliance.
- \* Put the freezer door on the bottom hinge.
- \* Turn the bottom hinge of the refrigerator door by 180°, insert the hinge and the washer into the hole of the corner cap on the freezer door and fasten it. Use the same procedure for the top hinge of the freezer door and screw it on the opposite side of the upper door. Put the washer and the upper door on the hinge.
- \* Screw the top hinge of the refrigerator door and replace the cover.
- \* Reposition the slide guides on the opposite side of both doors.
- \* Plug the remaining holes with the decorative caps.

# Mounting the appliance

Before mounting the appliance into the kitchen unit, disconnect the power supply and set the thermostat knob to the OFF (O) position.

Push the appliance for some 38mm into the kitchen unit and allow at least 4mm free space on both sides between the appliance and the side walls of the kitchen unit. (Fig.1)

Fig.1

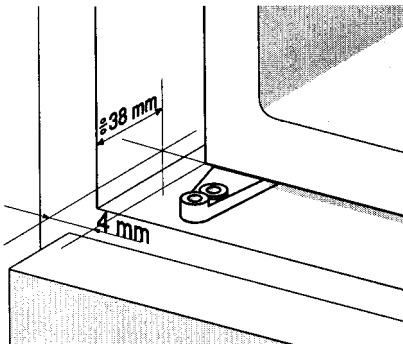

Open both doors as wide as possible and put them together with the door of the kitchen unit. The procedure is as follows;

- \* Put the appliance door and the door of the kitchen unit (Fig.2).

Fig.2

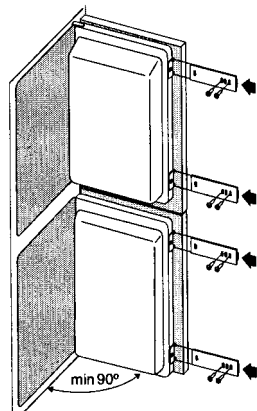

Insert the slides into the guides and fix them on the kitchen unit door some 15mm from the edge, using the A3,5 x 13 screws (Fig.3).

Fig.3

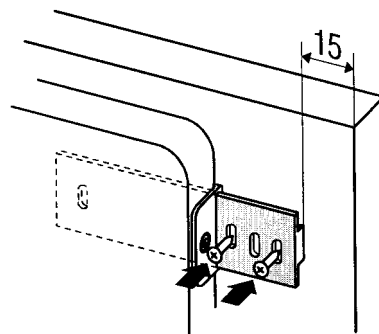

- \* Remove the side guides and separate the appliance door from the door of the kitchen unit.
- \* Fix the slides taking care not to move them (Fig.4).
- \* Fix the slides to the original position.
- \* Close the door and check that the gasket is not creased and the door opens smoothly

Fig.4

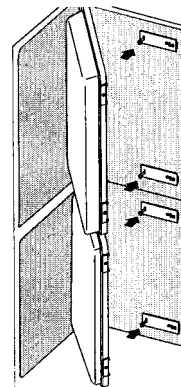

## Mounting the appliance

\* Fix the appliance into the kitchen unit. On the upperside, fix the three screws through the rail and on the lower side with 2 screws through the lower hinges. Drill holes  $\phi 2.5 \times 5$  (Fig.5).

Fig.5

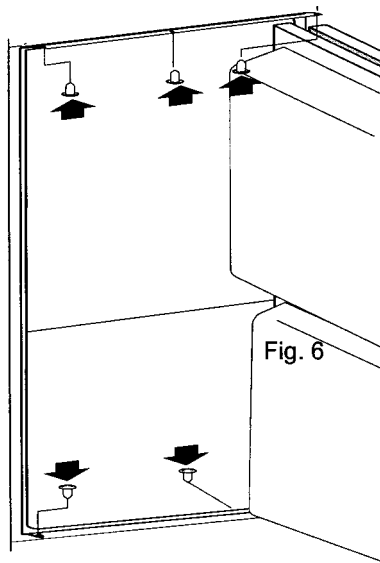

\* Seal the gap on the opposite side of the hinge with the enclosed seal (Fig.6)

Fig.6

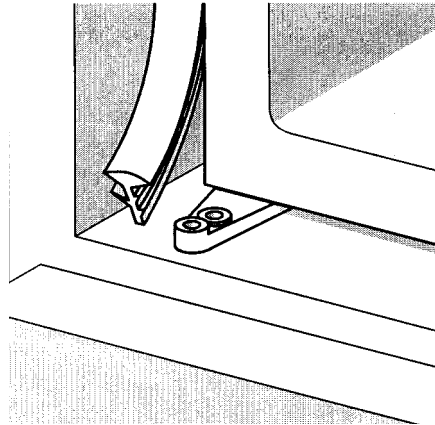



# Get to know your Appliance.

**WARNING: CHILDREN SHOULD NOT BE ALLOWED TO PLAY WITH THE APPLIANCE OR TAMPER WITH THE CONTROLS.**

BM 10

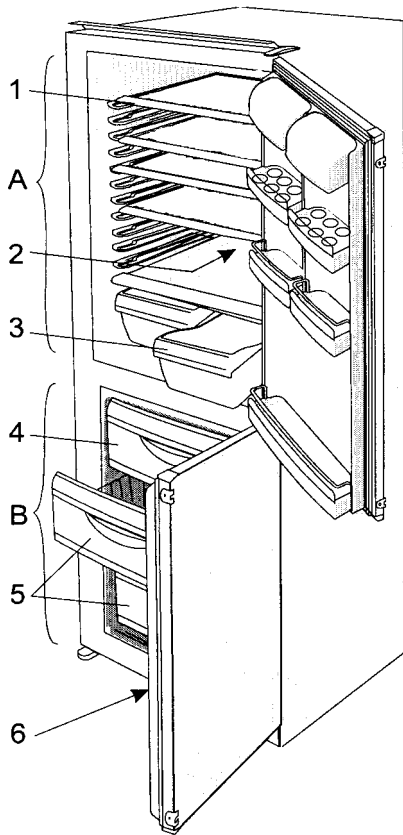

**A. 1. Shelf**  
The shelves are adjustable and can be pulled out and used on any of the guide slots. They can also be used in a tilted position to allow the safe storage of bottles, jars etc. on their sides. To tilt a shelf, place the back of the shelf on a lower slot than the front.

BM 21

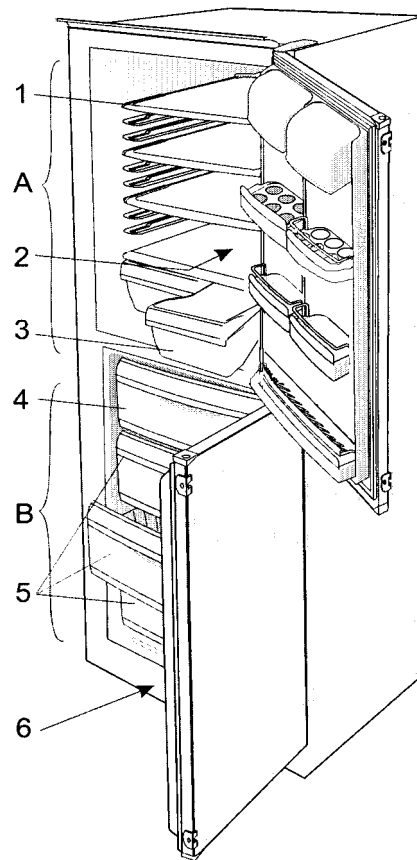

**2. The defrost water outlet**  
The interior of the refrigerator is cooled with a cooling plate incorporated in the rear wall. Under the plate there is a channel and an outlet for the defrosted water. Regularly check the outlet and channel for food deposits which could clog the drain hole. If the hole is blocked, use a plastic straw to clean it out.

## Get to know your Appliance.

### 3. Fruit and vegetable container

The container is under the glass at the bottom of the refrigerator and is mainly used to store fruit and vegetables.

### The door liner

The door liner consists of various shelves or holders used for storing eggs, cheese, butter and yogurt as well as other small packages, tubes, cans etc.

The lower shelf is used for storing bottles.

### The interior light

The light will come on when the door is opened.

### B.

### 4. Freezing compartment

This is used for freezing fresh food.

### 5. Storing compartment

This is used for storing packages of frozen foods.

### 6. Defrost water outlet

(see care and cleaning).

### Note:

Various accessories (depending on model) such as; spice container, tube holder or additional shelves can be bought from authorised centres

## Getting your Appliance ready for use.

Before connecting to the mains electricity supply leave the appliance to stand for 2 hours to allow the cooling system to settle.

Clean the appliance, and be thorough, especially in the interior. (see 'Caring for your Appliance).

### Final Check:

Before you start using your appliance check that:

- The appliance is level.
- It is thoroughly dry inside.
- There is adequate air circulation.
- Accessories are correctly placed in their positions.

### Running in the Compressor:

Your appliance is operated by a compressor which switches on and off in order to maintain the internal temperature.

The compressor requires a running in period of up to 2 months. During this time it has to work a little harder and may result in more noise than usual.

Noise levels are also determined as to the location of the appliance, what is stored and where the items are placed,

**Whether the compressor is running or not, it is normal to hear sounds created by the liquid and gases sealed within the system.**

## The Controls.

The temperature in both the fridge and the freezer is regulated by one thermostat which is located inside the top right of the fridge compartment.

Turn the control knob clockwise from the **OFF (O)** position to the required setting **1 - 7**.

### TEMPERATURE SELECTION -

Higher settings on the knob (towards **7**) mean lower temperatures (colder) in all compartments of the appliance. Temperature in the interior of the appliance may even drop below 0°C

When the ambient temperature is normal, we recommend medium setting.

Changes of the ambient temperature affect temperature in the interior of the appliance (choose the correct setting of the thermostat knob).

In the **OFF (O)** position the appliance does not operate (the cooling system is switched off), however the interior light will still operate when the door is opened.

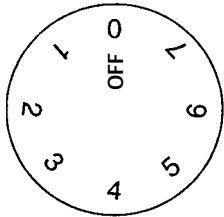

### INTEGRATED LOW AMBIENT/FAST FREEZE SWITCH -

The appliance has an integrated switch built into the control box housing, close to the thermostat knob.

**This switch should be turned on (switch illuminated), when the ambient temperature is lower than 20°C, to ensure normal operation of the appliance.**

When the integrated switch is activated the compressor will operate for longer periods, the refrigerator and freezer temperatures will therefore be colder than normal.

NOTE: Also refer to the freezing procedure.

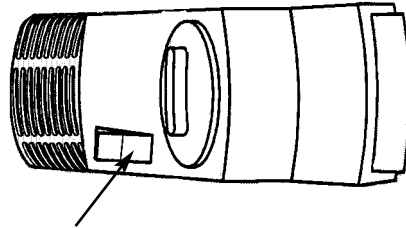

Low ambient / Fast freeze switch

## Storing Food.

### STORING FRESH FOOD:

Proper use of the appliance, adequately packed food, correct temperature and taking into account hygienic precautions will substantially influence the quality of the food stored.

- Foods to be stored in the refrigerator should be properly packed, to prevent drying out and odour transference. Plastic bags, containers with lids, foil and plastic stretch wrap are ideal.
- Wrap cheese firstly in greaseproof paper and then in a polythene bag, excluding as much air as possible. For best results take out of the fridge an hour before eating.
- Before storing food in the refrigerator, remove the excess packaging.
- Allow adequate air circulation around packages, make sure that foodstuffs do not touch each other (various odours may mix).
- Never store poisonous or dangerous substances. Your appliance has been designed for the storage of edible food stuffs only.
- Beverages with high alcohol percentage shall be stored in tightly sealed bottles in a vertical position.
- Position food to allow air to circulate freely, ensuring nothing comes into contact with the cooling plate at the rear of the refrigerator.
- Foods should be cooled down before storing.
- Quickly perishable foods should be stored at the back ie. the coldest part of the refrigerator.
- Try not to open the door too often.
- Wrap raw or defrosting meat and poultry in polythene or foil and store below cooked foods and dairy products.
- Clean out salad bins regularly and check that nothing has dripped into them.
- Keep food for as short a time as possible and adhere to 'sell by' dates.
- Store fruit and vegetables in the salad bins under the glass shelf as it provides a better humidity level for these items.
- Take off any unusable leaves on vegetables and wipe off any soil.
- Leave lettuce, cabbage, parsley and cauliflower on the stem.
- If you are going away, ensure that perishable foods are removed from the refrigerator before you leave.

### FRESH FOOD STORAGE TIME IN THE REFRIGERATOR:

FRESH FOOD	Recommended Storage Time	Possible Storage Time
Butter	1-7 days	1-12 days
Eggs	1-10 days	1-14 days
MEAT Fresh uncut	1-2 days	1-3 days
MEAT Chopped	1 day	1-2 days
MEAT Smoked	1-10 days	1-14 days
Fish	1 day	1-2 days
Marinade	1-10 days	1-14 days
Root	1-8 days	1-14 days
Cheese	1-4 days	1-14 days
Sweets	1-2 days	1-6 days
Fruit	1-2 days	1-10 days
Prepared dishes	1-2 days	1-4 days

## Storing Food.

### FREEZING FRESH FOODS -

- Carefully select food you intend to freeze: it should be of high quality and thoroughly cleaned before freezing it.
- Use correct packaging suitable for the freezer.
  - The packaging should be air tight and should not leak since this could cause substantial vitamin loss and dehydration of foods.
  - Foils and bags should be soft enough to wrap tightly around foods.
- Mark packages with the following data:
  - The kind and quantity of foods.
  - The date of loading.
- Prepare fresh foods for freezing in small quantities to ensure that the food freezes quicker and its quality does not deteriorate during thawing and preparation.
- Dry packs of food to be frozen so that they do not freeze together.
- The quantity of fresh foods that can be loaded in the freezer within 24 hours is indicated on the rating plate (freezing capacity). If the loaded amount is too large, the quality of freezing is reduced, which affects the quality of frozen foods.
- Don't put liquid filled bottles or sealed cans containing fizzy drinks into the freezer as they may burst.
- Don't try to keep food which has thawed, it should be eaten within 24 hours, or cooked and refrozen.
- Don't give children lollipops and water ices directly from the freezer, the low temperature may cause 'freezer burns' on their lips.

**FREEZING PROCEDURE** - Switch on the integrated switch for intensive cooling some 24 hours before loading the appliance with larger amounts of fresh foods and turn the thermostat knob to position 4-6. After 24 hours load the freezer with fresh food packages. After loading wait another 24 hours then switch off the switch and turn the thermostat knob to the required position (see Temperature Selection page 10).

### STORING FROZEN FOODS -

Store commercially frozen foods according to the manufacturer's recommended storage instructions as indicated on the packaging. When shopping select frozen foods last and be careful in choosing adequately packed foods. Wrap frozen food when you buy it and put it in the freezer as soon as possible. Don't buy packages of food with a frost layer, this indicates that the package has been at least partially thawed before.

### DEFROSTING FROZEN FOOD -

Partially thawed or defrosted food should be used as soon as possible. Cold air preserves the food but it does not destroy micro-organisms which rapidly activate after defrosting and make foods perishable.

### APPROXIMATE STORAGE TIME FOR FROZEN FOODS:

FOOD	Storage Time (in months)
Vegetables	8-10
Fruit	10-12
Bread, Pastries	3
Milk	3
Ready-made Meals	3
Meat Beef	10-12
Veal	8-10
Pork	4-6
Poultry	8-10
Game	6-8
Minced Meat	4
Smoked Sausages	1
Fish lean	3
fat	1
Offal	2

## Caring for your Appliance.

### DEFROSTING:

#### AUTOMATIC DEFROSTING OF THE REFRIGERATOR-

There is no need to defrost the refrigerator, because ice deposited on the interior back wall is defrosted automatically.

Ice is deposited on the interior back wall during the compressor operation, later on when the compressor is not operating, the ice defrosts and water droplets collect and drain through the outlet in the interior back wall into the drain pan situated above the compressor, from where it evaporates.

#### MANUAL DEFROSTING OF THE REFRIGERATOR-

As long as the defrost water runs to the channel and through the outlet to the drain pan on the compressor, automatic defrosting of the appliance is assured.

In the case of ice formation on the interior rear wall increasing (3-5mm), ice should be manually defrosted.

Set the thermostat knob to **OFF (O)** position and leave the refrigerator door open.

Never use electric devices for defrosting and do not scrape the ice with sharp objects.

After defrosting is completed, turn the thermostat knob to the desired position and close the refrigerator door.

The cause of increased ice formation may be one of the following:

- The door does not seal well. (Clean the gasket if it is contaminated or replace it if it is damaged).
- The door was frequently opened or was left open for a long period.
- The food stored in the refrigerator was warm.
- Food or packaging is touching the interior rear wall.

#### MANUAL DEFROSTING OF THE FREEZER-

When the frost and ice layer in the freezer is 3 - 5mm thick you should defrost the freezer.

- A few hours before defrosting, set the thermostat to position **7**, so that packages are well frozen.

Reset the thermostat to **OFF (O)** position and disconnect the power supply.

Empty the freezer, wrap frozen food in a blanket and put in a cool place.

- Insert the supplied pipe into the groove (the defrost water outlet) in the bottom of the appliance
- Place a vessel underneath to collect the defrost water. Defrosting is accelerated if the door is left open.

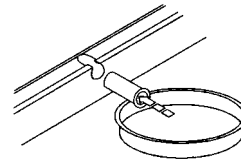

- Avoid using defrosting sprays, as they may cause damage to the plastic parts and may be hazardous to health.

#### REPLACING THE LIGHT BULB-

Should the light fail to work, switch off at the power point and pull out the plug. Remove the shelves to make access easier. Access to the bulb is from the rear of the cover (**arrow 1**) and remove the cover in the direction of (**arrow 2**).

Unscrew the old bulb. Screw the new bulb securely into the holder. Replace the plug in the power point and switch on. If the light fails to work, do not worry, it will not affect the working of your Larder Fridge. Obtain a replacement (max 15 watt 220-240V alternating current, E14 lampholder) from your nearest Spares Centre and replace the old bulb.

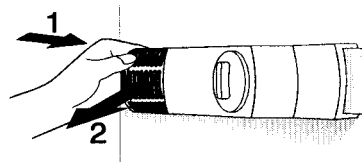

## Caring for your Appliance (cont).

### CLEANING THE APPLIANCE:

**WARNING: SWITCH OFF ELECTRICITY SUPPLY AND PULL OUT THE MAINS PLUG BEFORE CLEANING.**

**WARNING: DO NOT USE HOUSEHOLD CLEANERS, ABRASIVE POWDERS OR WAX POLISH. THESE NOT ONLY DAMAGE THE SURFACES, BUT ALSO LEAVE A SMELL WITHIN THE APPLIANCE.**

### GOING AWAY:

If you do not intend to use the appliance for a long period, set the thermostat knob to the **OFF (O)** position, switch off at the socket outlet and pull out the plug. Remove all food, follow defrosting instructions (page 13) and clean the appliance. Leave the door ajar to prevent the accumulation of odours.

- Clean the exterior of the appliance with warm water and a small amount of liquid detergent, dry thoroughly.
- Remove the detachable accessories in the interior of the appliance and wash in warm soapy water, dry thoroughly.
- Wipe the interior and fittings with a clean cloth wrung out in either a solution of one teaspoon of bicarbonate of soda to one pint water or Milton sterilising fluid, diluted according to manufacturers' instructions. Dry the interior thoroughly with a clean cloth before replacing fittings and food.
- Every now and then wipe the condenser on the rear wall of the appliance. Use a soft non-metal brush or a vacuum cleaner.

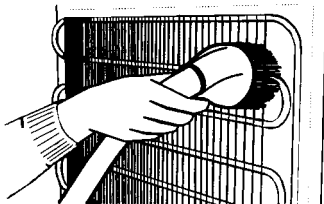

- Clean the drain pan on the refrigerator compressor. Do not remove the drain pan.

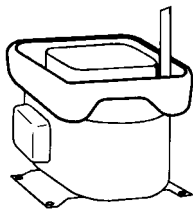

- Use warm, soapy water to wipe along and in between the creases of the door seal, dry thoroughly.

**WARNING: Do not use detergent it will damage the door seal.**

After cleaning reconnect to the power supply and switch on.

## Troubleshooting.

When checking an appliance you can come across some problems which are a result of improper handling of the appliance and can be easily eliminated.  
Run through this checklist before calling your nearest Service office.

The appliance won't work.	Check the plug is firmly positioned in the wall socket and the power supply is switched on. Check the power supply with another appliance. Check the fuse.
There has been a power failure.	<b>DO NOT OPEN THE FREEZER DOOR.</b> If power does not return within 16 hours, food should be removed from the freezer and either cooked and eaten within 24 hours or cooked and refrozen.
The appliance is making alot of noise.	Check the appliance is stabilised. Ensure the appliance is not touching the wall or kitchen units.
Continuous Operation of the Compressor	Has the door been opened frequently or for left open for a long period of time? The door is not closed properly/does not seal properly (clean the gasket if it is contaminated or replace it if it is damaged). Have you observed the maximum storage quantities? Check there is adequate air circulation.
Water is leaking from the refrigerator.	Check that the defrost water outlet is not blocked. (If blocked a plastic straw can be used to clear). Check that stored food or packaging is not in contact with the cooling plate on the interior rear wall of the refrigerator. (NB. It is normal for droplets to run down the cooling plate). Is there ice formation on the interior rear wall? (see 'Manual defrosting of the Refrigerator')
Refrigerator interior light does not work.	<b>SWITCH OFF AT THE SOCKET AND PULL OUT THE MAIN PLUG</b> , check the bulb is screwed in correctly. If it still doesn't work, replace the bulb (see 'Changing the Light Bulb').
The freezer door is difficult to open.	If you have just closed the freezer door, it may be particularly difficult to open again immediately. This is partly due to the difference in temperature between the room and the internal compartment. Wait 5 minutes for the external and internal pressure to equalise and try again.
Refrigerator and freezer compartments are colder than normal.	This is normal when the integrated low ambient switch is selected (illuminated).
The compressor runs for prolonged periods.	



## After Sales Service

### **Service Cover...**

We appreciate you choosing this quality appliance and we are sure that it will give you many years of excellent service.

Not only have you bought a first class appliance, you've also bought a commitment from us to look after your appliance.

We believe our Service is the best in the business and yet another good reason you'll be glad you chose this appliance.

Every appliance has been designed and manufactured to the highest standards. However, in the event of any problem developing, our trained professional engineers are just a phone call away with one real objective - to satisfy you by providing an efficient, effective and courteous service, at a time convenient to you.

### **Your Guarantee...**

The guarantee is subject to the provision(s) that the appliance:

- a) Has been used solely in accordance with the instruction book.
- b) Has been properly connected to a suitable electricity supply voltage as stated on the rating plate attached to the equipment.
- c) Has not been subjected to misuse or accident or been modified or repaired by any person other than an authorised employee or agent.
- d) Has been correctly installed.
- e) Has been used solely for domestic purposes and is on domestic premises.

Your guarantee is only applicable in the U.K. and the Republic of Ireland.

If you suspect a fault with your appliance, to avoid unnecessary inconvenience and expense please ensure that the checks detailed on 'Troubleshooting' on page 15 have been carried out before contacting the SERVICE NETWORK.

Should you require service our receptionist will require the following information:

- Your post code, name and address, type of appliance, model number. (found on the appliance rating plate or in the handbook).  
Guarantee/Contract/Insurance Policy Details.  
Date of Purchase, and where you purchased it from.

### **Easy Payment Methods...**

You can pay for any of our services offered either by Credit Card (Visa, MasterCard), Cheque and Debit Card. Or in installments by Direct Debit provided you include a Care Plus scheme.

#### **SERVICE U.K.**

08709 066 066

Monday - Friday 8am - 8pm,  
Saturday 8am - 6pm,  
Sunday 10am - 6pm.

#### **Republic of Ireland**

1850 302 220

Monday - Friday 8am - 5.30pm,  
Saturday 9.00am - 12.30pm.

# Guarantee

## High quality after-sales service levels...

- **IN GUARANTEE (Year 1)**  
All appliances carry a FREE fully inclusive 12 months parts and labour guarantee. If service under your Year 1 Guarantee is required please have available evidence of your date of purchase when the engineer calls.
- **OUT OF GUARANTEE (Years 2-10)**  
Once an appliance is over 12 months old, and goes out of guarantee, we offer you a very simple choice of service levels:

**CARE LEVEL 1:** No advance fee payable, no registration necessary. Should a repair be needed in years 2-10, (i.e. over 12 months old) your Regional Service Centre will advise you of the fixed labour charge we will make. Although this charge will vary according to your location and the type of appliance you own, **it is fixed regardless of the time taken or the number of visits needed to complete the repair.** The cost of parts where required will be charged additional to the fixed labour charge, but again this cost will have a maximum level of which you will be advised by your Regional Service Centre. The repair itself is fully guaranteed for 12 months.

**CARE LEVEL 2:** Annual fee payable all inclusive cover provided. You may prefer the peace of mind of an all-inclusive type of cover: this is provided by our Care Plus Scheme which, for an annual fee covers the cost of any parts or labour. This applies on appliances up to 10 years old. For your convenience this fee can be paid in installments by Direct Debit. Payments can also be made by Credit Card (Visa, MasterCard), Cheque and Debit Card.

**CARE LEVEL 3:** Kitchen Cover  
For an extra fee, you can also purchase Kitchen Cover for all of our brand appliances you own, provided they are under 10 years old. To join simply call **08709 088 088** and register.

**EASY ACCESS REPAIR SERVICE**  
One number - **08709 066 066** connects you automatically to your U.K. Regional Service Centre to arrange for your local engineers to call. Office opens 7 days a week, 364 days a year, Monday - Friday 8am - 8pm, Saturday 8am - 6pm, Sunday 10am - 6pm. For the Republic of Ireland call **1850 302 220**, Monday - Friday 8am - 5.30pm, Saturday 9.00am - 12.30pm. This is the largest appliance manufacturer service team in Europe. Trained specialists covering all our appliances (and directly employed by us). If contacted before 10am, we try to offer a service call the same day where required or the next working day. (Monday to Friday). On request, your service call can be the first or last of the day with am or pm timings always available. We can also cater to meet your specific needs ie. avoiding school hours whenever we can. A chargeable service is offered on the basis of payment on completion to our service engineer, who will issue a receipt.

Our Service Engineers drive recognisable vans, wear uniforms and carry identity cards. Our Service Engineers will only fit genuine parts.

### ANSWER CENTRE

Information and advice regarding specific appliance features and pricing on any of our appliances, before or after purchase.

From anywhere in the U.K., telephone **08701 50 60 70** from 8.45am - 5.30pm, Monday - Friday.

### PARTS NATIONAL MAIL ORDER HOTLINE

The Parts Mail Order Hotline enables you to order parts directly from the manufacturer over the phone. A wide range of parts and accessories are available for your appliance.

**Telephone: 08709 077 077 Fax: 0541 532 532**

**Republic of Ireland Parts Telephone: 01 842 6836**

**Monday - Friday 8.30am - 5.30pm, Saturday 8.30am - 12 noon.**

Ring quoting your appliance model number and we will help you get the right parts. National Warehouse comprehensively stocked over 33,000 parts lines. Parts stocked for all models. Parts carried for all appliances up to 10 years old, (15 on Heating appliances). Optional 24 hour express courier service. (Additional charge).

### CARE FOR THE DISABLED

We offer a range of accessories which enable our blind arthritic or disabled customers to use most of our appliances. Simply call **08709 077 077** and provide the model number details.



# ***Key Contacts***

## ***Service***

***UK: 08709 066 066***

***Republic of Ireland: 1850 302 220***

You will be asked for the following information:-

Name, address and postcode.

Telephone number

Model / Serial number of the appliance

Clear and concise details of the query or fault

Place and Date of purchase

(Please keep the receipt as evidence will be required when the engineer calls).

## ***Extended Warranty***

***To join: UK 08709 088 088***

***Republic of Ireland: 1850 302 220***

## ***Genuine Parts & Accessories Mail Order Hotline***

***UK: 08709 077 077***

***Republic of Ireland: (01) 842 6836***

For further product information 08701 50 60 70

All Services are offered as an extra benefit and do not affect your statutory rights.

General Domestic Appliances Limited, Morley Way, Peterborough, PE2 9JB

Part No. FP068-01